

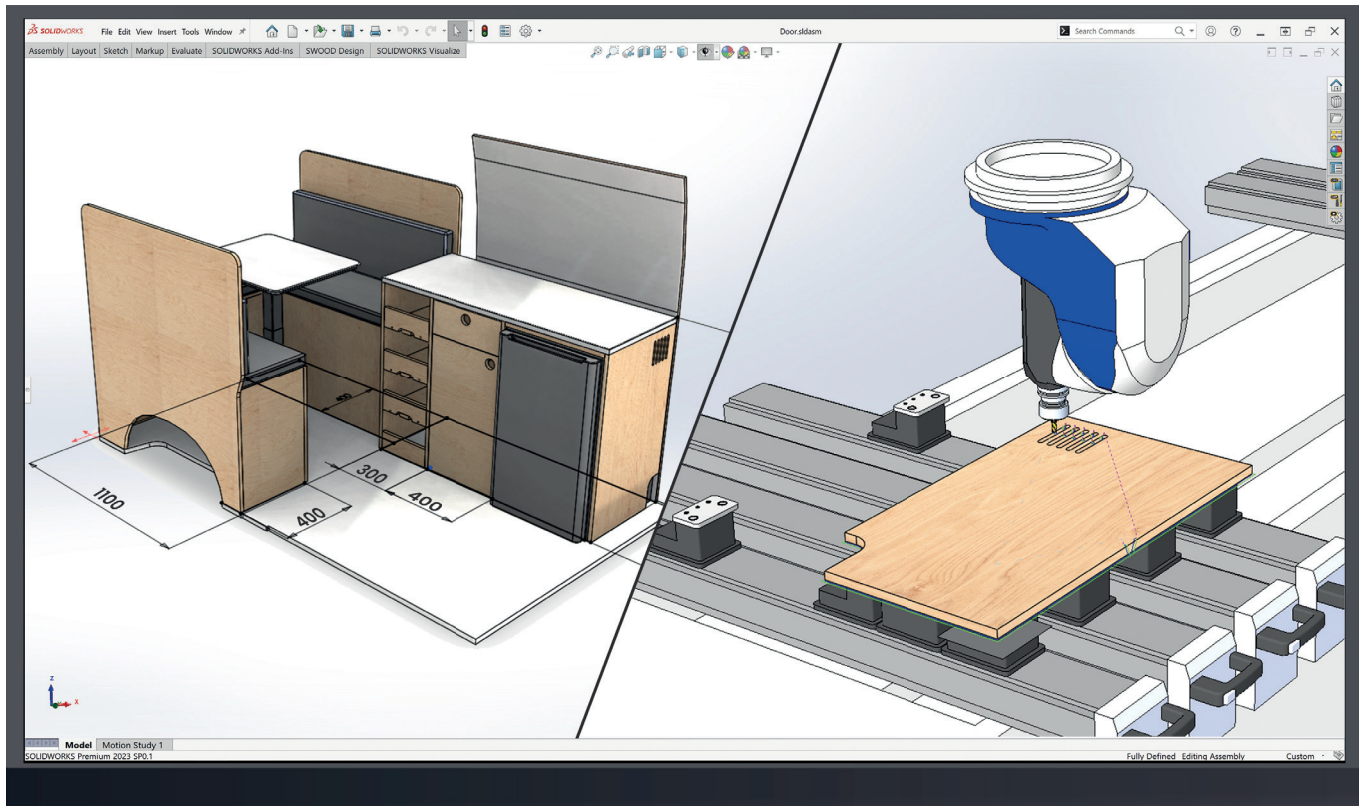

by EFICAD

# CAD CAM SOFTWARE DEDICATED TO WOODWORKING



**DESIGN**

**MANUFACTURE**

**AUTOMATE**

[www.swood.eficad.com](http://www.swood.eficad.com)



# SWOOD

## ALL-IN-ONE SOLUTION

SWOOD is an all-in-one solution developed to meet the specific challenges of the woodworking industry. Integrated within SOLIDWORKS, the solution's specific features focus on three steps of the woodworking process: design, manufacture, and automate. Our solution guarantees a seamless flow of information at every process stage.

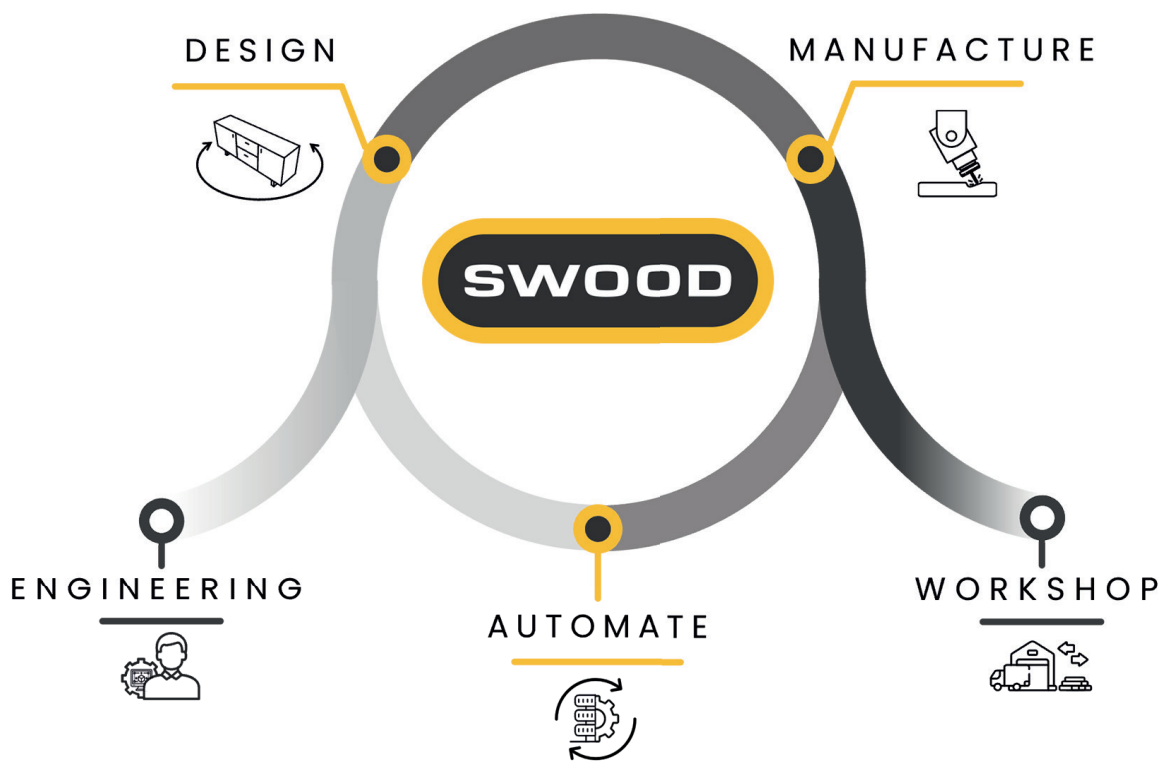

### DESIGN

Design your most complex 3D wood projects without limits, in an intuitive, parametric environment developed specifically to handle wood materials and their specificities. Collaborate easily thanks to project document generation, 2D and 3D drawings, renderings, etc.

### MANUFACTURE

Generate dedicated CNC programs and production documents for all your 3D projects. SWOOD's advanced algorithms enable you to control point-to-point machining and nesting strategies without the risk of errors between design and manufacturing.

### AUTOMATE

Using the parametric capabilities and shape recognition of the design and production solutions, the automation solution generates reliable information on high-volume batch production based on order data lists.

# SWOOD INTEGRATION WITHIN SOLIDWORKS

The SOLIDWORKS solution offers advanced 3D parametric features and technical responses to the most complex mechanical engineering projects. Its intuitive environment and worldwide presence make it the reference software for Computer Aided Design (CAD) in industrial sectors.

Integrating SWOOD's wood functions into this environment completes and adapts the SOLIDWORKS technical solution to meet the woodworking industry's needs.

The solution's ecosystem is present at all key stages of the project. Data management based on detailed 3D models makes design processes more reliable. Project approvals are simplified thanks to the creation of realistic visuals and technical drawings. Production stages are also made more reliable by generating programs and production documents. Assembly instructions and drawings finalize the project and complete the digital chain.

**CERTIFIED**  
Gold  
Product

**SOLIDWORKS**

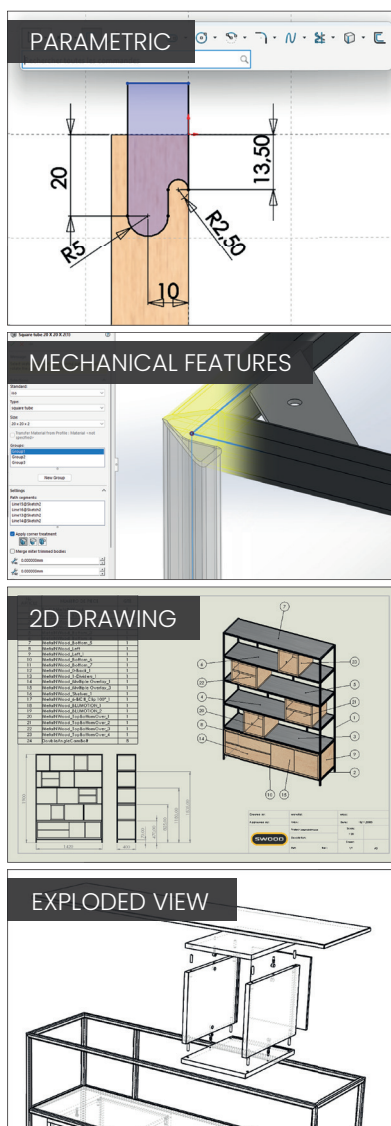

Thanks to its presence in the education system and worldwide network of resellers, the SOLIDWORKS community now has over 6 million trained users.

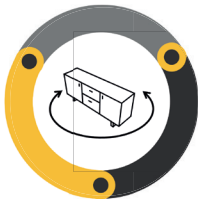

# DESIGN

## ADVANCED PARAMETRIC FEATURES

Use wood-specific features in an ergonomic, parametric environment to design your most complex 3D projects. Streamline your design processes and save your company know-how by storing your rules and models in libraries.

Machining integration right from the design stage ensures high reliability. Compilation of design data enables collaboration with different departments throughout the project.

### TOTAL DESIGN FREEDOM

#### PARAMETRIC CAPABILITIES

Create any complex structure. Thanks to the solution's parametric capabilities, customization is made easy and changes are automatically applied to the entire project according to predefined rules.

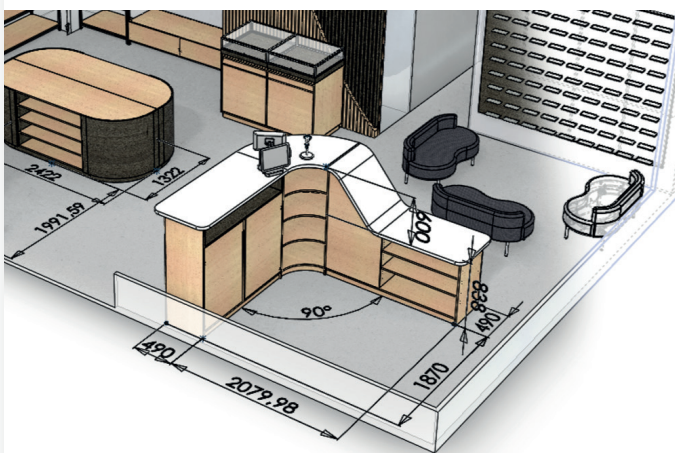

#### MULTI-MATERIAL

SWOOD integrates multi-material projects by combining its wood functions with SOLIDWORKS functions, such as weldments, sheet metal, resin, plastics, etc., in a single interface.

### STREAMLINE REPETITIVE TASKS

#### LIBRARIES

- Save your company know-how and maintain consistency in your projects by creating your own library elements with settings and predefined rules.
- Library Installer allows you to download components with all supplier specifications and technical parameters for immediate project use.
- Drag and drop library components that will automatically propose the most optimized configuration based on the insertion context.

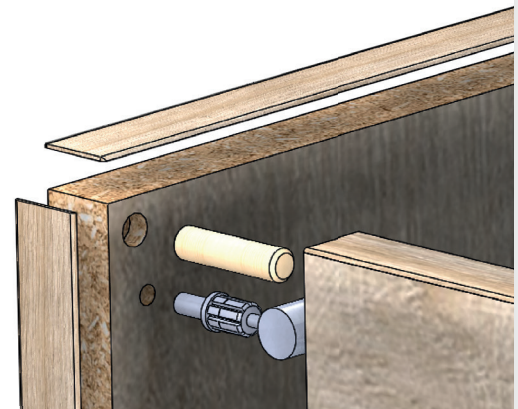

All library-saved element integrate their associated machining, reducing the risk of manual errors and making production more reliable.

#### HARDWARE

Drag-and-drop hardware components from leading brands, such as drawers, hinges, handles and more. Save design time by reusing these elements.







## COMPLETE MATERIAL CONTROL

Define your materials and modify them in your projects without constraints.

### PANELS

Manage all panel parameters, such as grain direction, thickness, stock extensions, and panel composition (laminated, multi-layer, edgebanding, etc.).

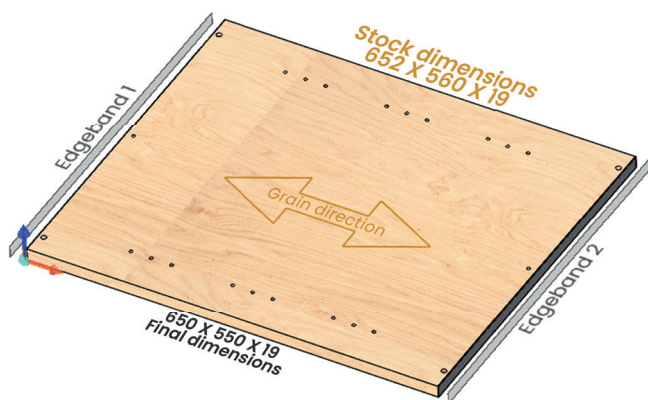

### EDGEBANDING LIBRARIES

Define the edgeband shapes, thickness, material, and more, in the library to apply to all the projects at once. Change the edgebands' application order at any moment.

## CENTRALIZED PROJECT INFORMATION

### REPORT

Produce your 3D projects without the risk of errors.

The software automatically collects all design element parameters, enabling a project report to be generated for production, including :

- material and hardware requirements
- machining programs
- panel lists
- stock lists, and many more.



Any parameter change made in the design is applied to programs and documents, enabling their generation in one click.

The export of these documents is fully customizable, and outputs documents in various file formats: XLS, PDF, CSV, HTML, XML, and the like, thus streamlining information transfer.



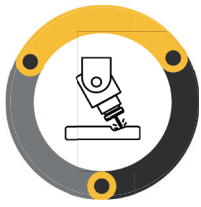

# MANUFACTURE

## WORKSHOP PRODUCTION DATA

From 3D projects to production data for the workshop, our solution translates all project parameters for your woodworking machines.

Our production solution translates all 3D project parameters into workshop documents and CNC programs. Based on shape recognition and wood-specific machining strategies, SWOOD provides the answer for point-to-point and nesting.

### FROM DESIGN TO MANUFACTURING

#### GEOMETRIC RECOGNITION

Shape recognition capabilities allow to detect 3 and 5 axis machining operations. Tool paths are optimized according to predefined and customizable strategies and compiled into programs.



Design changes are instantly detected, and all part toolpaths are updated in programs in one click.

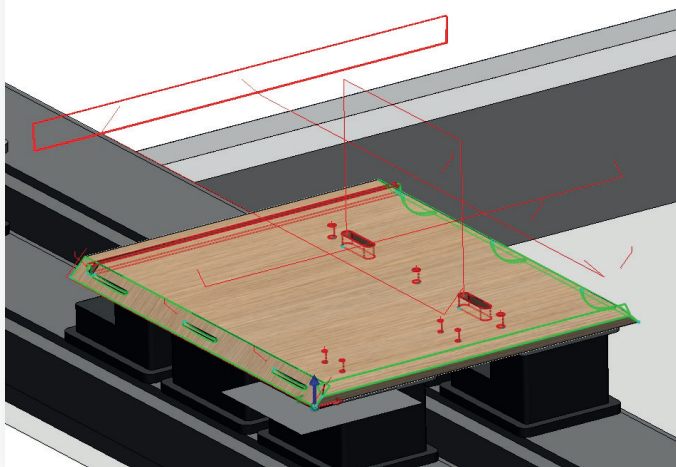

### WOOD CNC EXPERT

#### POST-PROCESSOR

Export your toolpaths to your CNC with our post-processors, which are available for:

- HOMAG (WoodWOP)
- BIESSE (BiesseWorks, bSolid, ISO)
- SCM (XOLOG, MAESTRO, ISO)
- Felder (TPA, F4Integrate)
- HOLZHER (NC HOPS), and many more.



The development of our own post-processors over the last 30 years ensures optimum machine compatibility.



### CENTRALIZED PROJECT INFORMATION

#### REPORT

Send all the programs to the CNCs in one click to optimize the manufacturing process.

Link the engineering office with the workshop by generating detailed production documents (cutting lists, tool lists, labels, and so forth).

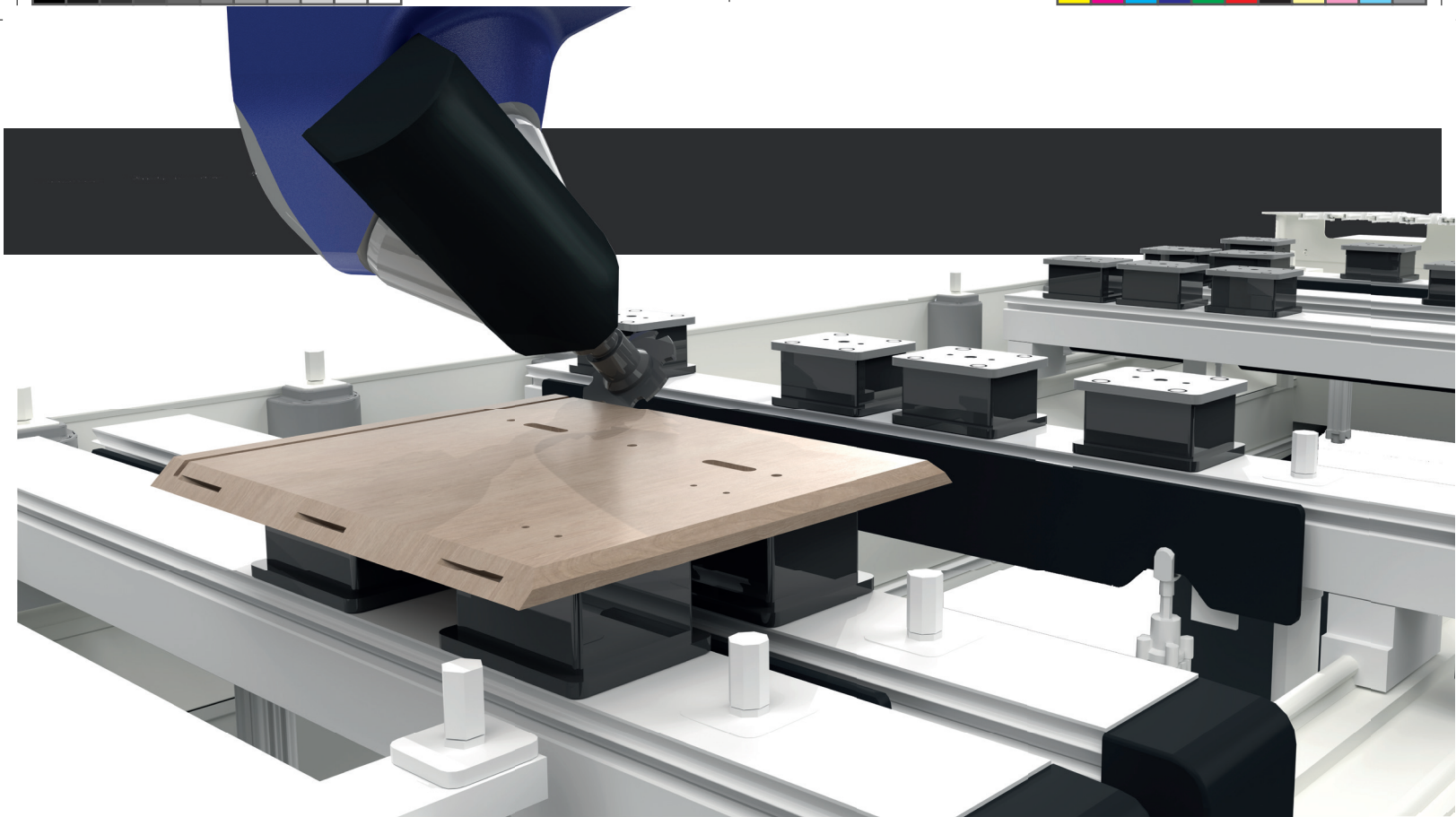

# PROCESS ADAPTABILITY

## POINT-TO-POINT

Our manufacturing solution supports woodworking CNC machines and their unique technologies.

Easily connect the design information to the CNC machines by generating the necessary programs and production documents.

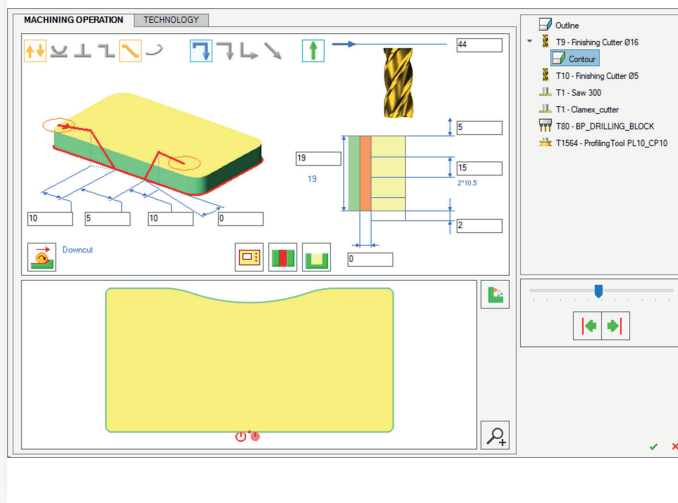

## NESTING

In addition to comprehensive machining strategies, our nesting solution empowers you to overcome complex production challenges.

Nest multiple projects to optimize production.

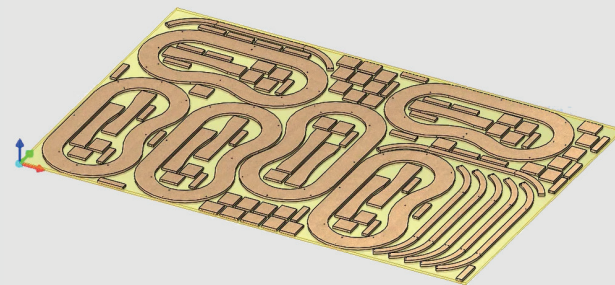

After calculating the first nesting result, it is still possible to :

- Manually modify part positions
- Add trajectory jumps (bridges)
- Modify the lead in/lead out point
- Modify panel numbering (labels)



# MACHINING STRATEGIES

## COMPLEX SHAPE CAPABILITIES

### UP TO 5 AXIS

Manage 3 to 5 axis programs according to your project needs, easily creating roughing and finishing operations to program any shape.

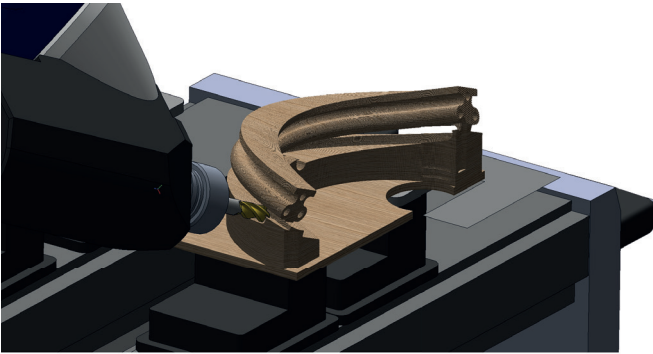

Our in-house 5 axis algorithms for 3D milling allow to generate tool paths specific to woodworking.

### SIMULATION

Pre-production simulations allow you to preview the complete program with the material removal function and the machining environment to detect all potential collisions between head, table, tool and workpiece, from stock to finished part.

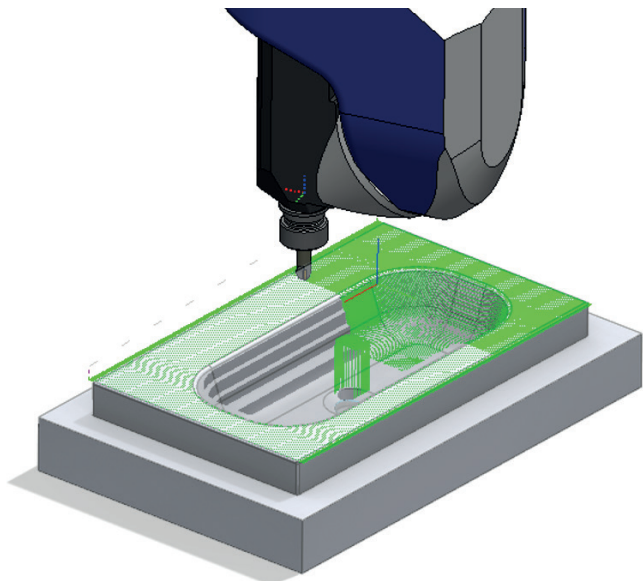

## NESTING PART HOLDING STRATEGY

Nesting-specific strategies ensure optimal part holding to prevent them from moving during milling.



- **Milling order** is optimized starting from the smallest to the largest parts at the end of the program.
- **Automatic bridge insertion** according to part size allows to link parts together, thus preventing them from leaving the nesting sheet.
- A **forbidden area** is created to prevent the smaller components from being placed too close to the board's edges to maintain optimum suction on these parts.

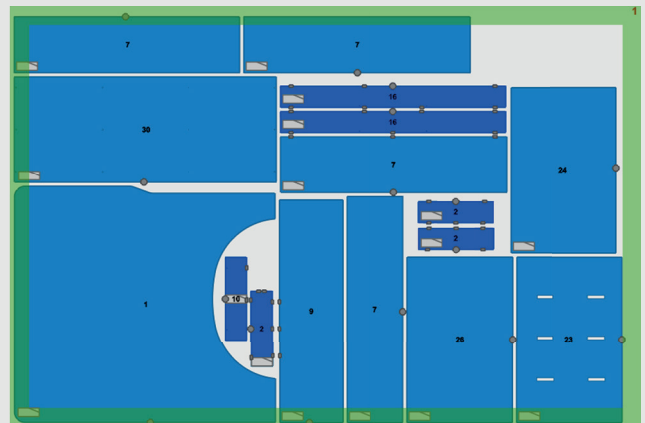

Our nesting solution also offers strategies such as minimizing the cutting force with the onion skin strategy and using the staydown contour operation, which optimize trajectories and save up to 20% of milling time.



# MACHINE TECHNOLOGY

## TECHNOLOGY COMPATIBILITY

### MACHINE

Our solution is able to export information for machine specificities or other workstations, such as :

- Edgebanding aggregates
- Profiling tools for joinery
- Drilling blocks
- Cardan and fork heads
- Deflectors
- Hardware insertion machines and many more.

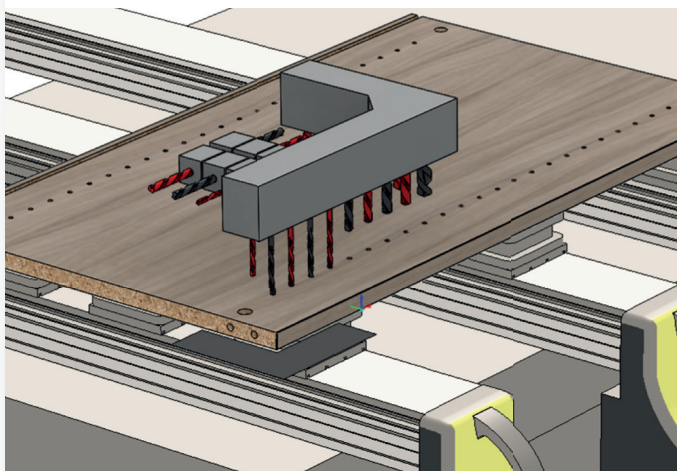

### WORKTABLE

To guarantee the correct position of the holding systems before machining, SWOOD controls motorized machining tables: rail and pods, clamping systems, laser systems, and so on.

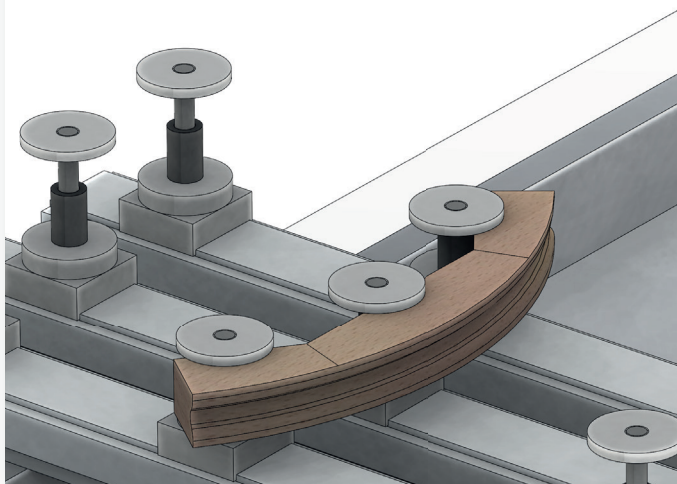

## NESTING MATERIAL MANAGEMENT

### GRAIN MATCHING

Linked to the design solution, you can match several front parts grain direction of a project to facilitate their nesting and respect the project's aesthetic constraints.

### MANAGE REMAINING BOARD MATERIAL

#### • OFFCUTS

Detect, cut, and reuse offcuts automatically! Define the minimum size of offcuts to detect them and create cutting paths automatically.

#### • FILLERS

Incorporate recurring parts as *fillers* to fill up the remaining space on your nesting sheets, enabling you to produce and store frequently used parts, therefore saving time for future projects.

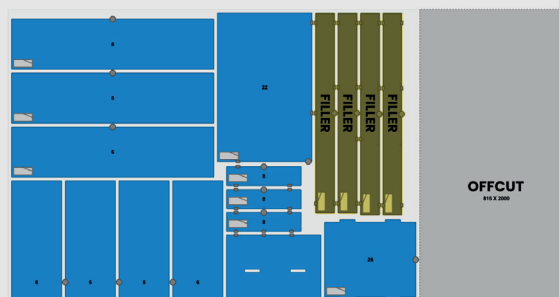

Cut in small pieces the remaining material to simplify manual offcut handling or automatic extraction.

## PANEL IDENTIFICATION

### LABELS

Easily identify parts, offcuts, and fillers with the generation of detailed labels for the panel projects.



Define label position and orientation for CNC-integrated printers.

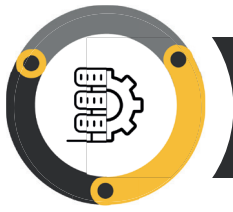

# AUTOMATE

## PRODUCTION DATA GENERATION

Export, in one click, a complete report to streamline the process by establishing a direct link between SWOOD, the workshop, the company's information system, and other departments.

This report ensures the reliability of production data by compiling project information throughout the design process.

It includes the main information required for wood production. The layout of the documents can be customized, and specific information can be added on demand.

### BOM – MATERIAL DATA

All necessary information for the production are extracted from the 3D models, such as:

- **Cutting list** for panel beam saw optimization software
- **Hardware list** for the purchasing department
- **Bills of materials** to forecast material quantities
- **Costs information** to optimize project profitability
- Information on **specific operations** (varnishing, veneering, sanding, etc.)
- And many more.

#### Panel information

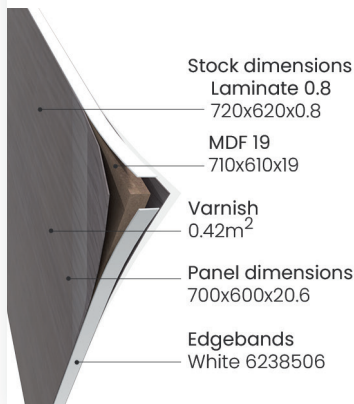

#### Hinge information

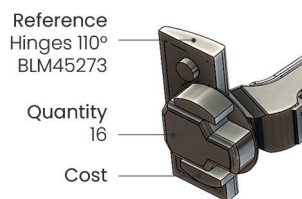

### READY-TO-RUN PROGRAMS

Centralize all the programs generated for the project thanks to the report. Once your design is complete, start production right away.

Programs are generated based on custom parameters for CNCs, to be compatible with:

Wood-WOP, BiesseWorks, bSolid, ISO, XILOG, MAESTRO, TPA, F4Integrate, NC HOPS, and many more.

### SPECIFIC WORKSHOP DOCUMENTS

Other production information, such as: 2D drawings, tool lists, labels, nesting reports, 3D documents, rails and vacuum pod positions, and many more, are exported in the report to enhance collaboration.

1	DESC	LENGHT	WIDTH	QTY	MATERIALE	EBF	EBB	EBL	EBR	COMMENT
2	Panel	994	2747	1	MDF 19					
3	Panel_1	994	2747	1	MDF 19					
4	Partition1	1960,4	628,4	1	MDF 19	Generic EI	Generic EI	Generic EI	Generic EI	Generic EB 0.8mm None Grain
5	Partition1	502,4	628,4	1	MDF 19	Generic EI	Generic EI	Generic EI	Generic EI	Generic EB 0.8mm None Grain
6	Partition2	502,4	628,4	1	MDF 19	Generic EI	Generic EI	Generic EI	Generic EI	Generic EB 0.8mm None Grain
7	Partition1	2234,4	628,4	1	MDF 19	Generic EI	Generic EI	Generic EI	Generic EI	Generic EB 0.8mm None Grain
8	Bottom	985,5	639,07	1	MDF 19					
9	Front	969,5	40	1	MDF 19					
10	Front_2	969,5	40	1	MDF 19					
11	Front_3	969,5	40	1	MDF 19					
12	Front_4	969,5	40	1	MDF 19					
13	Front_5	969,5	40	1	MDF 19					
14	Shelf	985,5	639,07	1	MDF 19					
15	Shelf_1	985,5	639,07	1	MDF 19					
16	Shelf_2	985,5	639,07	1	MDF 19					
17	Shelf_3	985,5	639,07	1	MDF 19					
18	Left	2770	660	1	MDF 19					
19	Right	2751	660	1	MDF 19					
20	Top	2077	760	1	MDF 19					

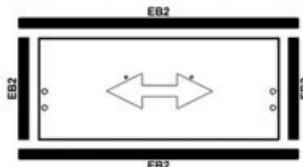

Export the documents in various file formats: XLS, PDF, CSV, HTML, XML, TXT, and the like, allowing communication with other systems in the company (ERP, MRP, MES, etc.).

# ADVANCED AUTOMATION

Connected to an external data system, SWOOD's automation solution automatically generates high-volume design and production information. Using the parametric capabilities and shape recognition of design and production solutions, SWOOD recalculates projects from order data. Provide your workshop with reliable, detailed data without manual action.

## FROM EXTERNAL DATA SYSTEM

ERP / Planner / Sales Configurator / and more.

Create a design catalog thanks to the parametric features of our design solution. An in-house customized application collects order information from your third-party software into SWOOD.

This can import orders from your database on a recurring basis (daily, weekly, at every new order, and so on).

## THROUGH SWOOD

### 3D MODELS



Once collected, SWOOD will automatically rebuild the design project according to the information provided during the first step, without any manual action.

New geometries are detected and tool paths updated as the design is modified.

### PROGRAMS

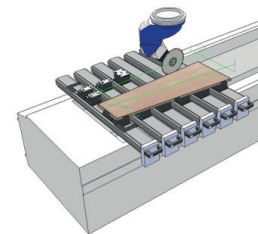

### REPORT

Programs and production documents (panel lists, hardware lists, programs, and more) are generated for each production batch.

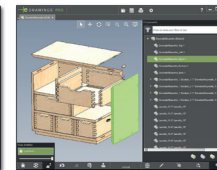
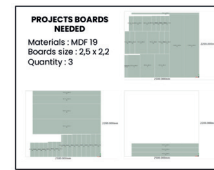
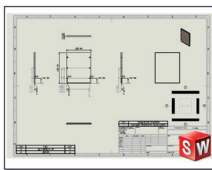
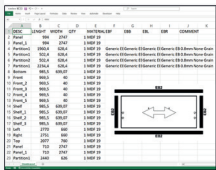

## TO PRODUCTION DATA

Collected project information can be forwarded to the company's information system for order tracking, purchasing, and the like. Data export is fully customizable to collaborate easily with other departments.

The workshop can then use the production reports (hardware list, stock list, etc.) and associated programs related to the customer's order data. This automated workflow ensures high-volume, reliable production information.

# SWOOD ECOSYSTEM

## A DEDICATED WOODWORKING SOLUTION

To enhance our CAD/CAM solution, we have successfully collaborated with various industry suppliers, incorporating essential 3D elements such as hardware, library components, and machines.

### MACHINE SUPPLIERS

Post-processors are created in collaboration with machine manufacturers and customized or adapted by SWOOD's experts to meet specific CNC requirements, guaranteeing a smooth, seamless workflow.

### WOOD CONNECTOR INTEGRATION

Long-standing collaboration with the industry's leading suppliers enables us to include 3D connectors, their production and machining specifications, and the associated material removal for reliable assembly design.



### HARDWARE REFERENCES

EFICAD works closely with hardware industry suppliers, such as BLUM, HETTICH, GRASS, along with others, and ensures the users have access to the latest innovation in a ready-to-use SWOOD file format used in SOLIDWORKS.

SWOOD Library Installer, a scalable CAD content platform allows you to download updated and new items on a day-to-day basis.

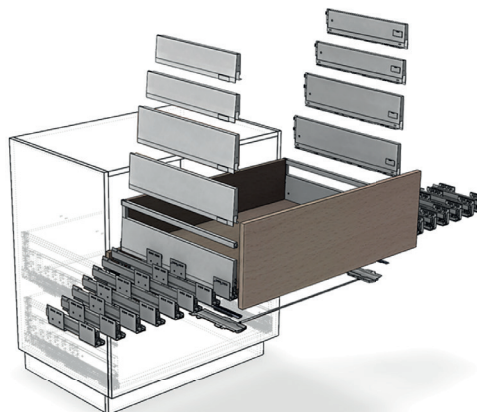

Intelligent components, available for download, streamline the process by suggesting the best hardware configuration based on the insertion context and applying drilling patterns for the efficient and reliable creation of complex projects.

### SWOOD CONNECT

SWOOD Connect empowers its users by providing them with an array of features that allow easy import and export of information to and from external platforms. With this powerful tool, users can easily connect to industry-leading platforms, such as **E-SERVICES from Blum Group**, **productionManager from HOMAG**, **Winner from Compusoft Group**, and many more that are upcoming, thus opening a world of possibilities.



# CLIENTS TESTIMONIALS

## THEY TRUST US FOR THEIR WOODWORKING PROJECTS

### BEAUBOIS

#### ARCHITECTURAL MILLWORK

CANADA: 500+ EMPLOYEES



Facing the challenge of improving the efficiency of their projects, Groupe Beaubois embraced technological advances and integrated automation and robotization into their plant. They realized that their design software played an essential role in facilitating the flow of information for their equipment and teams.

"Before acquiring the software, they [EFICAD] proved that SWOOD could help us grow"

The solution has provided the tools and capabilities to transform their methodologies and establish a common language throughout the organization.

With SWOOD solution, Groupe Beaubois experienced a significant boost in their productivity and efficiency.



#### SWOOD Design integration

Étienne Pilote-Fortin, in charge of the design team at Beaubois, highlights the advantages of SWOOD solution, "It helped us input more information into the model so that the builder or the rest of the team could put it together without much training".

The solution allowed Groupe Beaubois to create parts with Lego®-like shapes, facilitating rapid assembly and reducing the need for extensive drawings.

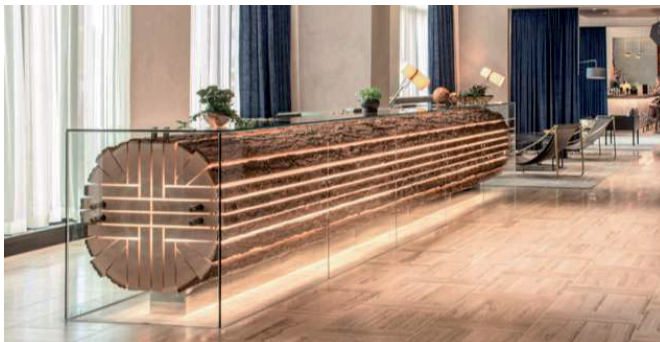

#### SWOOD CAM integration

The software significantly accelerated the start of production and the programming of their machines. Tasks that previously took hours can now be completed in a matter of minutes.

"Automatic machining recognition is the tool that helped us. The volume of parts would increase, and in the programming department, we needed a solution that automatically and efficiently creates many programs on different machines."

Stéphane Lesage - Director of Operations

With SWOOD, Groupe Beaubois has successfully harnessed technological advancements, improved efficiency, and embraced the future of architectural woodworking. Implementing SWOOD has paved the way for Groupe Beaubois to reach new heights and confidently take on ambitious projects.

# CLIENTS TESTIMONIALS

## THEY TRUST US FOR THEIR WOODWORKING PROJECTS

For over 30 years, EFICAD has been developing industry-specific solutions for woodworking. Developed for all types of companies involved in designing and manufacturing wood products, our solutions keep evolving to offer a unique response to the challenges woodworkers face. SWOOD is now a central tool of our users' design and manufacturing processes worldwide.



### MVS

#### INTERIOR FITTING

GREECE : 50-100 employees

"We had difficulties communicating our 2D drawings; there was information missing from one point to the other when making changes, and we had to do the same thing multiple times."

"We can see what we're drawing. It completely changed how we work. Also, we're working much faster as SWOOD has the feature of automatic dimensioning. It allows us to work quickly, and spend more time thinking by drawing less."

Vasilis Skandalis - Design Engineer



### LIGNE ROSET

#### FURNITURE

FRANCE : 500+ employees

"3D representation of machines and machining operations enables us to assess the feasibility of projects. Automatic generation of technical documents and standardization of machining operations with the machining entity library have enabled us to improve our processes."

Sylvain Ruet - CAD/CAM Methods Technician

**ligne roset**  
depuis 1860

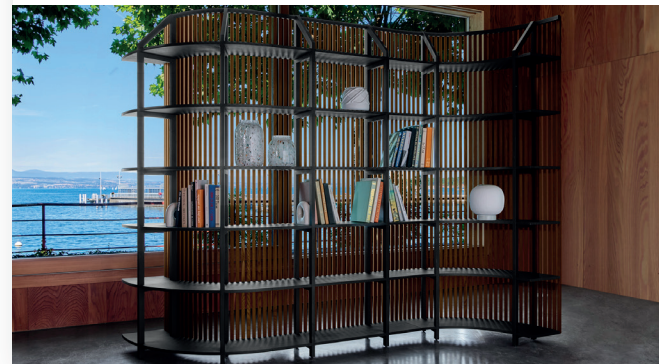

### KINZEL - JOINERY

USA: 20-50 EMPLOYEES

"SWOOD CAM is specific to the wood industry and runs on SOLIDWORKS. EFICAD is great to work with, they are available and help improve our programs when we need them."

Jesse Kinzel - Partner

**KINZEL**  
WOOD PRODUCTS LLC





## CARRIAGE



### VEHICLE INTERIOR FITTING

FRANCE: 20 - 50 EMPLOYEES

"Thanks to SWOOD, the finish quality of our products has really improved. The SWOOD products are high quality, they open space to imagine a lot of possibilities for our projects. The every year updates are also highly appreciated."

Loïc Gaden - Managing Director



## FRANCIS&CO



### RESIDENTIAL CABINETRY

USA: 5 - 10 EMPLOYEES

"The fact that we're able to take it from the design process directly to the machine. There's no in-between software that we must use to basically streamline the process. It's all in one step."

Nicholas Tvrdeich - Owner



## DIAM - SHOPFITTING



WORLDWIDE: 500+ EMPLOYEES

"SWOOD is a tool that allows us to keep lean information by creating a shorter bridge between the design process and the manufacturing process. This makes us more efficient in the total development of our projects."

Eduardo Rodríguez Gutiérrez - Manager





# ABOUT US

## A COMPLETE WOODWORKING SOLUTION

Developed at EFICAD's head office in France, SWOOD has established itself internationally thanks to its American subsidiary and over 83 certified partners. Located in over 60 countries, these partners have joined the network to distribute and support SWOOD solutions locally in a highly technical environment. More than 400 certified experts provide local customer service with the common aim of automating design and manufacturing processes. These users range from woodworkers with a single CNC to international groups and industry 4.0 companies.

### CERTIFIED PARTNER



info@beacon-india.com  
+91 74066 63589  
beacon-india.com/swood/

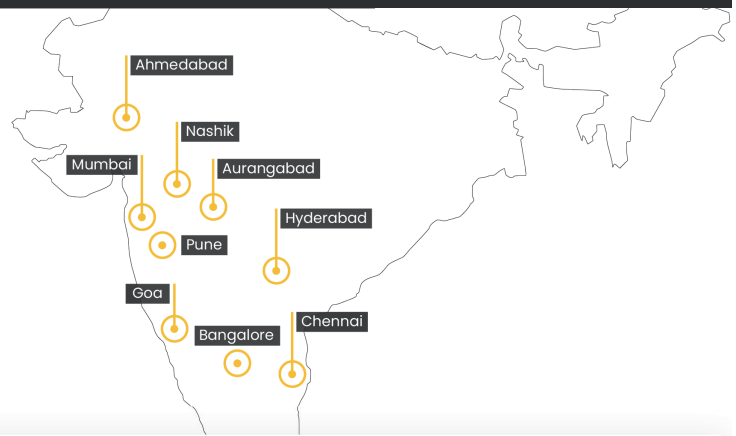

DESIGN		Parametric capabilities	Material management	Component libraries	Complete design report
		Shape recognition	Worktable management	Specific tool libraries	Program generation
		Automatic nesting	Part holding strategies	Multi-project optimization	Nesting report
		Third party software integration	Parameter computation	Digital chain communication	Production report generation